

PRODUCT INFORMATION PACKET



Model No: B2854V1
Catalog No: B2854V1

Pool Pump Motor, 1.5 HP, 1 Ph, 60 Hz, 115/230 V, 3600 RPM, Y56Y Frame, DP



Regal and Century are trademarks of Regal Rexnord Corporation or one of its affiliated companies.
©2022 Regal Rexnord Corporation, All Rights Reserved. MC017097E





Nameplate Specifications

Output HP	1.5 Hp	Output KW	1.1 kW
Frequency	60 Hz	Voltage	115/230 V
Current	SF 16.0/8.0 A	Speed	3450 rpm
Service Factor	1.1	Phase	1
Duty	Continuous	Insulation Class	F
Frame	Y56Y	Enclosure	Drip Proof
Thermal Protection	Thermally Protected	Ambient Temperature	50 °C
UL	Recognized	CSA	Y
Number of Speeds	1		

Technical Specifications

Electrical Type	Permanent Split Capacitor, Single Or Dual Voltage	Starting Method	Across The Line
Poles	2	Rotation	Counterclockwise Pump End
Mounting	Round	Motor Orientation	Horizontal
Drive End Bearing	Ball	Opp Drive End Bearing	Ball
Frame Material	Rolled Steel	Shaft Type	1/2 Thread
Overall Length	12.95 in	Frame Length	8.50 in
Shaft Diameter	0.625 in	Shaft Extension	0.91 in
Outline Drawing	OL56100695-001	Connection Drawing	17536729.PCX

This is an uncontrolled document once printed or downloaded and is subject to change without notice. Date Created:11/29/2022

D

C

B

A

D

C

B

A

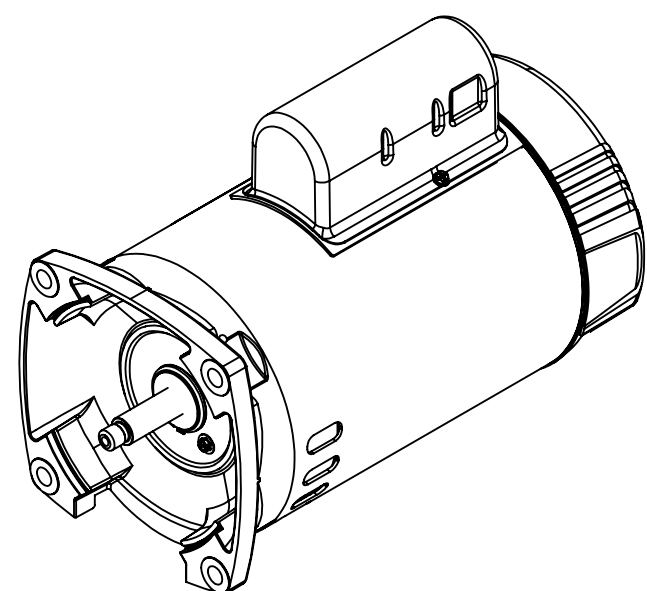
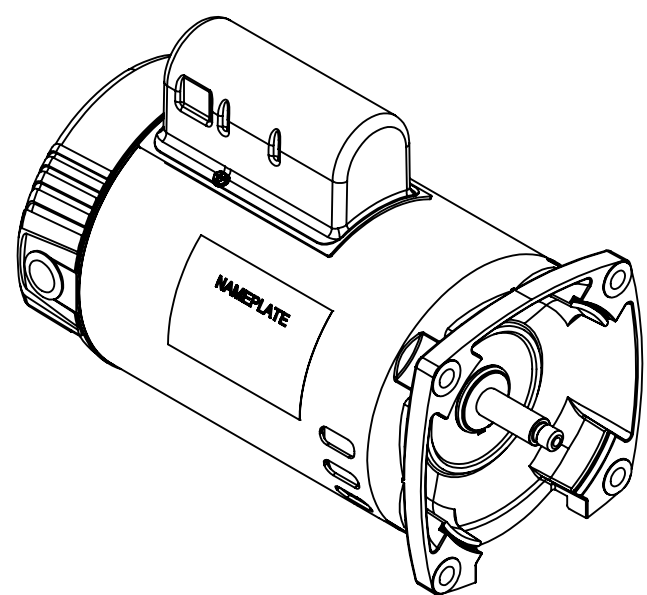
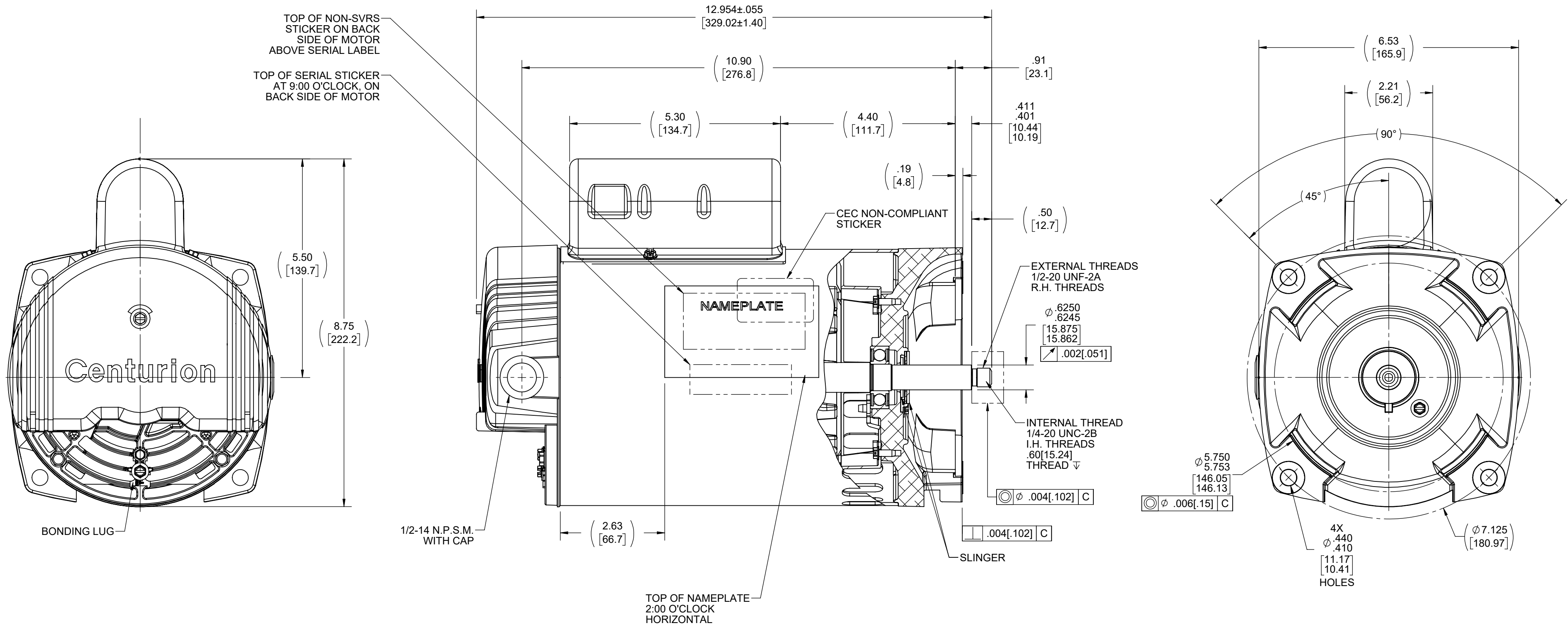

DRAWING REVISION E	REVISION BY SAI	REV DATE/© DATE 11/08/2021	TOLERANCES (EXCEPT AS NOTED):		DRAWN BY D.SURYAWANSHI	Regal Beloit America, Inc.	
REQUEST NUMBER	APPROVED BY D.SURYAWANSHI	DATE 11/08/2021	DEC. .X ±0.1 [±3] ±0.5°	INCH .XX ±0.02 [±0.5]	DATE 06/12/2019		
REQUEST NUMBER DESCRIPTION			.XXX ±0.005 [±0.13]	mm .XXX ±0.005 [±0.13]	APPROVED BY	DESCRIPTION	
COPYRIGHT (PER REVISION DATE) REGAL BELOIT AMERICA, INC. ALL RIGHTS RESERVED. PROPRIETARY AND CONFIDENTIAL INFORMATION - THIS DOCUMENT IS THE PROPERTY OF REGAL BELOIT AMERICA, INC. ("OWNER") AND CONTAINS OWNER'S PROPRIETARY INFORMATION. ANY PERSON, CORPORATION OR OTHER FIRM RECEIVING IT IS DEEMED, BY RECEIVING IT, TO AGREE THAT IT, AND/OR ANY PART OF IT, SHALL NOT BE DISCLOSED TO ANY PERSON, CORPORATION OR OTHER ENTITY, DUPLICATED, AND/OR USED, EXCEPT AS EXPRESSLY APPROVED IN WRITING IN ADVANCE BY OWNER. THIS DOCUMENT SHALL BE RETURNED TO OWNER UPON REQUEST. IT MAY BE SUBJECT TO CERTAIN RESTRICTIONS UNDER APPLICABLE EXPORT CONTROL LAWS AND REGULATIONS.			REMOVE BURRS & BREAK SHARP EDGES: .003/.015 [.08/.38] X 45°		DATE	OUTLINE MODEL-CFHP-56FR	
			CORNER FILLETS: R.02 [.5]		MACHINED SURFACES: .125/ mm 3.2 INCH/mm		REFERENCE OLME190838
			mm DIMENSIONS IN [BRACKETS] ARE FOR REFERENCE ONLY		THIRD ANGLE PROJECTION	SIZE C	DRAWING NUMBER OL56100695-001
							SHEET 1 OF 1